

EFHD FUEL FILTERS 200S-942W

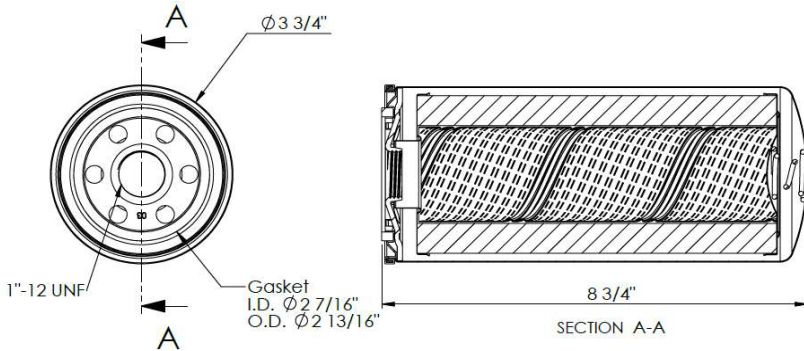

EQUIPCO[®]
INNOVATIONS IN FUEL HANDLING

www.equipco.com.au



MADE IN USA

DESIGNED TO MOUNT ON LARGE OVERHEAD STORAGE TANKS OR PUMPS

Specifications

Maximum Working Pressure:	50 psi
Flow Range:	94 lpm
Maximum Diff. Pressure:	25 psid
Media	2μ Hydroglass

200S-942W

- 94LPM
- 50 PSI max pressure
- 2 micron water absorbing element
- Replacement element for 200S-942W-25
- Petrol, 100% Biodiesel, diesel/ Bio diesel blends up to 20%, ULSD. Hydroglass

Average Filtration Efficiency (ISO 16889)

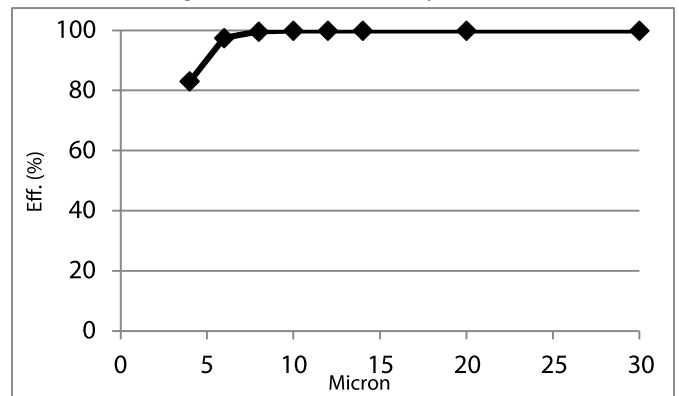

Reference Performance Values

B _{<4} = 2	B ₄ = 5.91
B _{4.5} = 10	B ₆ = 40.8
B _{6.6} = 75	B ₁₄ = 14963
B _{6.8} = 100	
B _{7.5} = 200	