

DO NOT SCALE

4 SIZES AVAILABLE

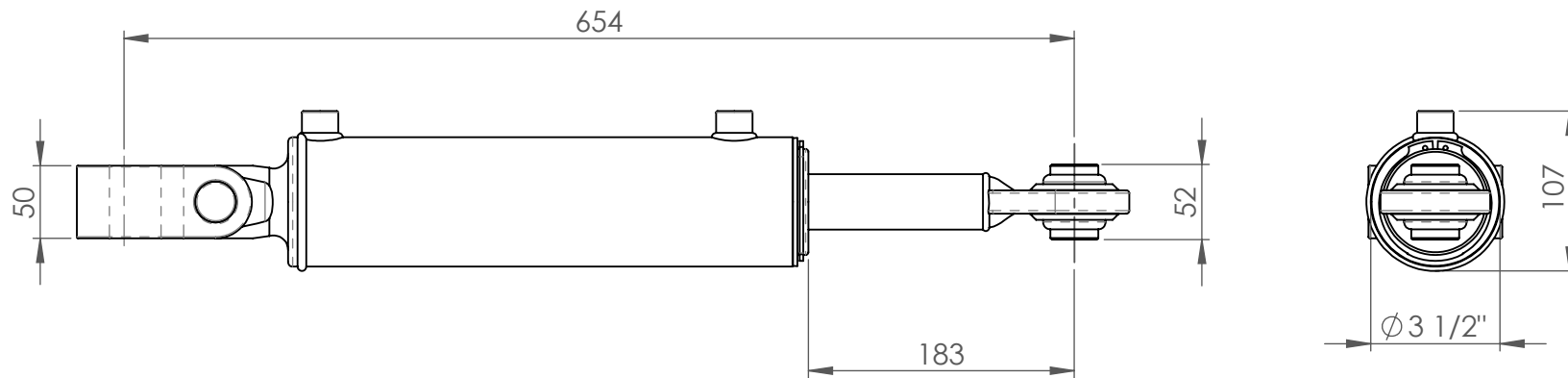
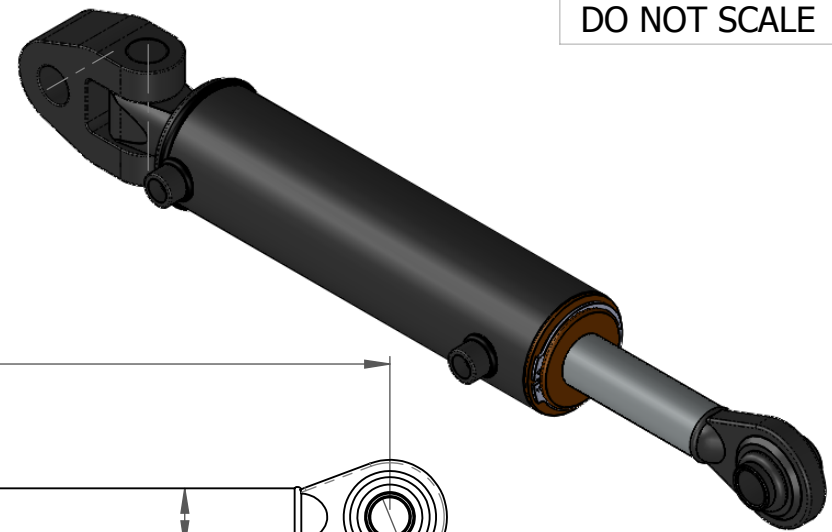
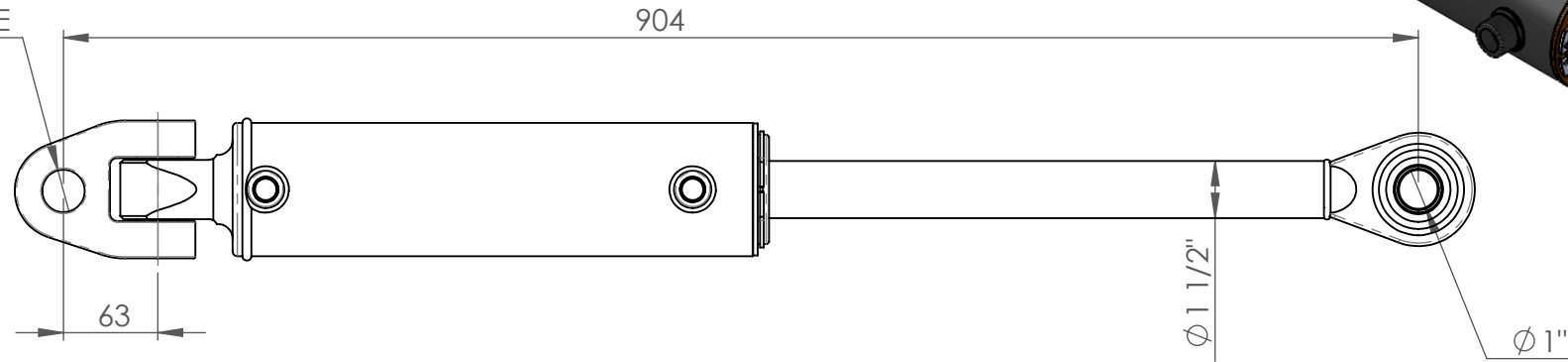

The information contained in this drawing is proprietary to MOTUS and shall not be reproduced or disclosed in whole or in part or used for any design or manufacture except when such user possesses direct written authorisation from MOTUS

Ram Phone: 0800 66 88 74
 Phone: +64 6 879 8590
 sales@motushydraulics.co.nz
 www.motushydraulics.co.nz

DESCRIPTION	TL-H1		
SEAL KIT No:	SK300150		
FORCE EXTENSION	7060kg @ 2250psi	FORCE RETRACT	5300kg @ 2250psi
STROKE	250mm	PORTS	3/8" FM BSPP
CLOSED CENTRES	654mm	BASE MOUNT	KNUCKLE
OPEN CENTRES	904mm	SHAFT MOUNT	1" BALL END (CAT 2)