



HEAVY DUTY GRADER BLADE



The new Heavy Duty Grader Blade from Collier & Miller features heavy plate construction and large diameter pins to withstand strenuous dirt forming operations, making it ideal for building and repairing roads.

Hydraulic operation to offset the blade and swivel in two directions provides a versatile selection of blade positioning.

Speak to Collier & Miller regarding more information and pricing for our Heavy Duty Grader Blade.



FEATURES & BENEFITS

- 12mm Plate Mould Board on 10' and 12'
- Fully Welded
- Full Hydraulic Operation
- 5" High Tensile Pin for Horizontal Blade Swivel
- Cat-3 / Cat-4 Linkage
- Replaceable Cutting Edges
- Powder Coated Finish



Collier & Miller has over seventy years' experience in designing and manufacturing quality agricultural and industrial equipment. This product is Australian Made & Owned.



www.colliermiller.com.au

- AGRICULTURE
- CME Farm Machinery
- Landforming Machinery

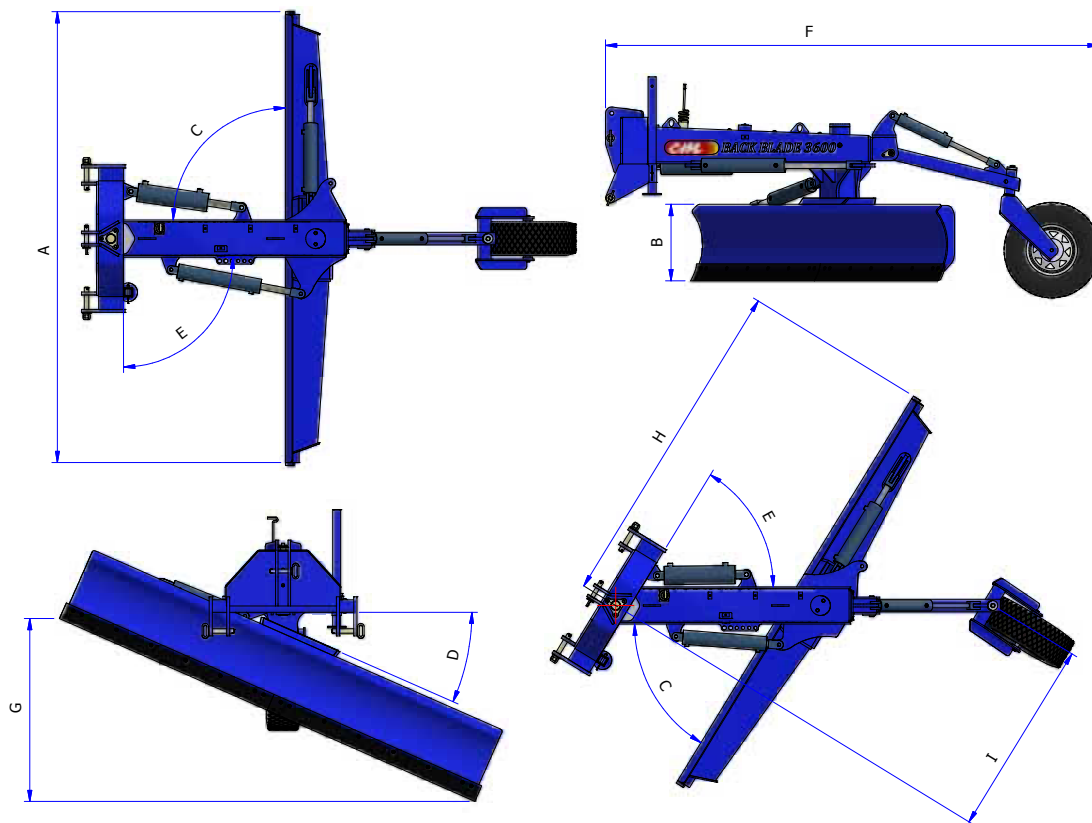

MODEL	CMBB8	CMHDBB10	CMHDBB12
DESCRIPTION	8' Grader Blade	10' Grader Blade	12' Grader blade
BLADE WIDTH	A=2400	A=3000mm	A=3600mm
BLADE HEIGHT	B=532mm	B=600mm	B=600mm
BLADE ANGLE DEG	C=58 deg	C=59 deg	C=59 deg
BLADE TILT DEG	D=21.5 deg	D=24 deg	D=24 deg
BLADE SLEW DEG	E=58 deg	E=59 deg	E=59 deg
OVERALL LENGTH	F=3026mm	F=3730mm	F=3730mm
BLADE HEIGHT AT FULL TILT	G=894mm	G=400mm	G=475mm
FULL SLEW DISTANCE TO BLADE TIP	H=2015mm	H=2290mm	H=2590mm
FULL SLEW DISTANCE TO WHEEL CENTRE	I=1341mm	I=1550mm	I=1550mm
WEIGHT KG	940 kgs	1750 kgs	1850 kgs
CATEGORY LINKAGE	Cat3	Cat3, Cat4	Cat3, Cat4
TYRE SIZE	RTY14HTW	31 x 10.5 R15	31 x 10.5 R15
GRADER BLADE	1 X 8' X 6" X 5/8"	2 x 5' x 6" x 5/8"	2 x 6' x 6" x 5/8"
POWDER COATED FINISH	Yes	Yes	Yes
BUILT IN SHEAR PIN SAFETY	NO	Yes	Yes
GREASE ABLE PIVOT PINS	Yes	Yes	Yes
MINIMUM TRACTOR HORSE POWER	80	150	150

QUOTED PRICE

