

COTTON BALE GRAB



An addition to our cotton implement range is our Cotton Bale Grab which has a heavy duty construction to ensure it performs day in day out.

Special features include a Dual-Arm frame powered by two hydraulic rams and four heavy duty wheels to protect bales in lifting action.

Speak to Collier & Miller regarding more information and pricing for our Cotton Bale Grab.



FEATURES & BENEFITS

- Heavy Duty Construction
- Dual-Arm Frame To Prevent Flexing
- Twin Hydraulic Ram System
- Four Heavy Duty Wheel Rollers To Protect Bales
- Heavy Base Plate For Stability When Lifting
- Suits Cat-3 /Cat-4 Quick Hitch



Collier & Miller has over seventy years' experience in designing and manufacturing quality agricultural and industrial equipment. This product is Australian Made & Owned.



www.colliermiller.com.au

- AGRICULTURE
- CME Farm Machinery
- Cotton Handling Equipment

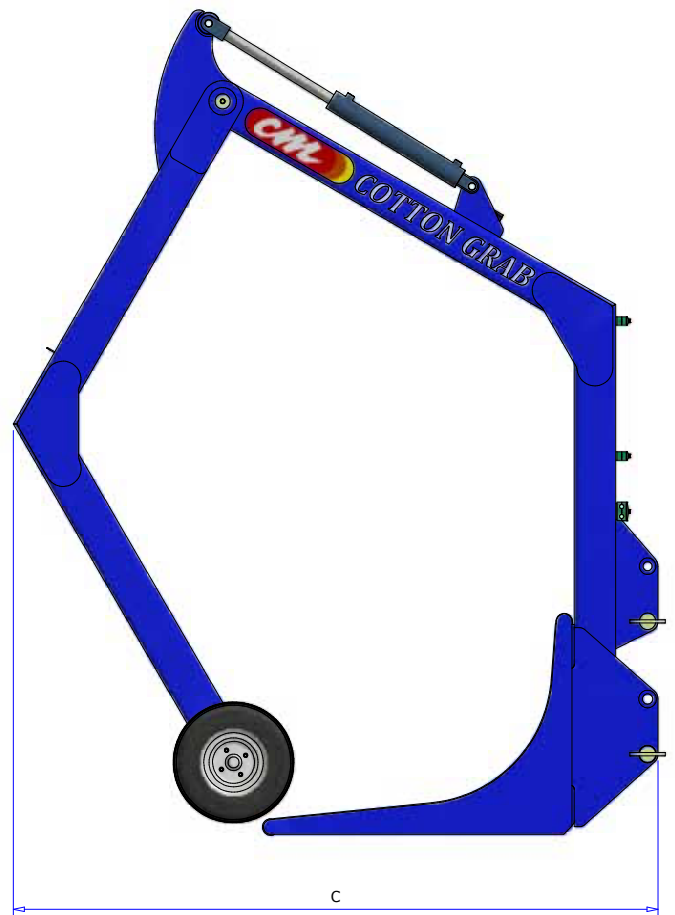
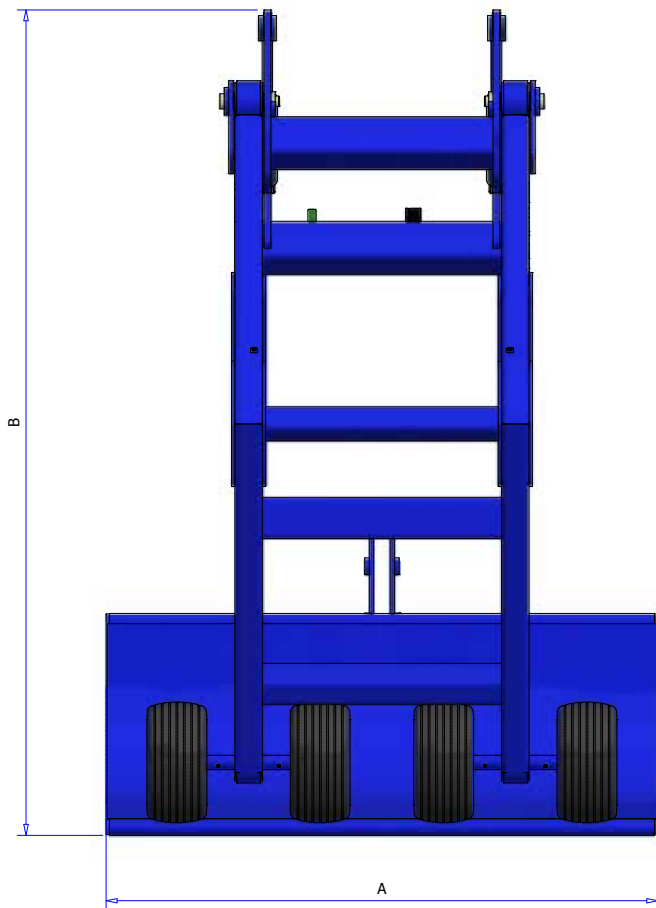

MODEL	CMCBL
DESCRIPTION	Cotton Bale Grab
OVERALL WIDTH A	2000mm
OVERALL HEIGHT B	3000mm
OVERALL LENGTH C	2350mm
NUMBER OF CLAMPING WHEELS	4
WEIGHT KG	1300kgs
CAT 3 LINKAGE	Yes
HYDRAULIC CYLINDER SIZE	2.5" dia x 16" stroke
GREASEABLE BALL BUSHES IN HYDRAULIC RAM PIVOTS	Yes
GREASEABLE PIVOTS	Yes
NUMBER OF HYDRAULIC REMOTES REQUIRED	1 Set
OPTIONS	
CAT 4 LINKAGE	Yes
ELECTRIC OVER HYDRAULIC CONTROL	Yes

