



8ft (2400)
GB8658 GRADER BLADE 8X6X5/8
 1 REQ



10ft (3000)
GB5658 GRADER BLADE 5X6X5/8
 2 REQ



12ft (3600)
GB6658 GRADER BLADE 6X6X5/8
 2 REQ



14ft (4200)
GB7658 GRADER BLADE 7X6X5/8
 2 REQ

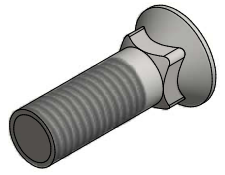

PLOW BOLT + SPRING + NUT
PB58X200ZP
 PLOW BOLT AND NUT ZP UNC
SW58ZP
 5/8 X 2 GRADE 9 HI TENSILE
 SPRING WASHER 5/8" ZINC PLATED

8ft (2400)
 10 REQ

10FT (3000)
 14 REQ

12FT (3600)
 16 REQ

14FT (4200)
 18 REQ

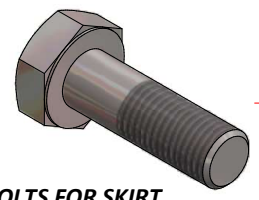
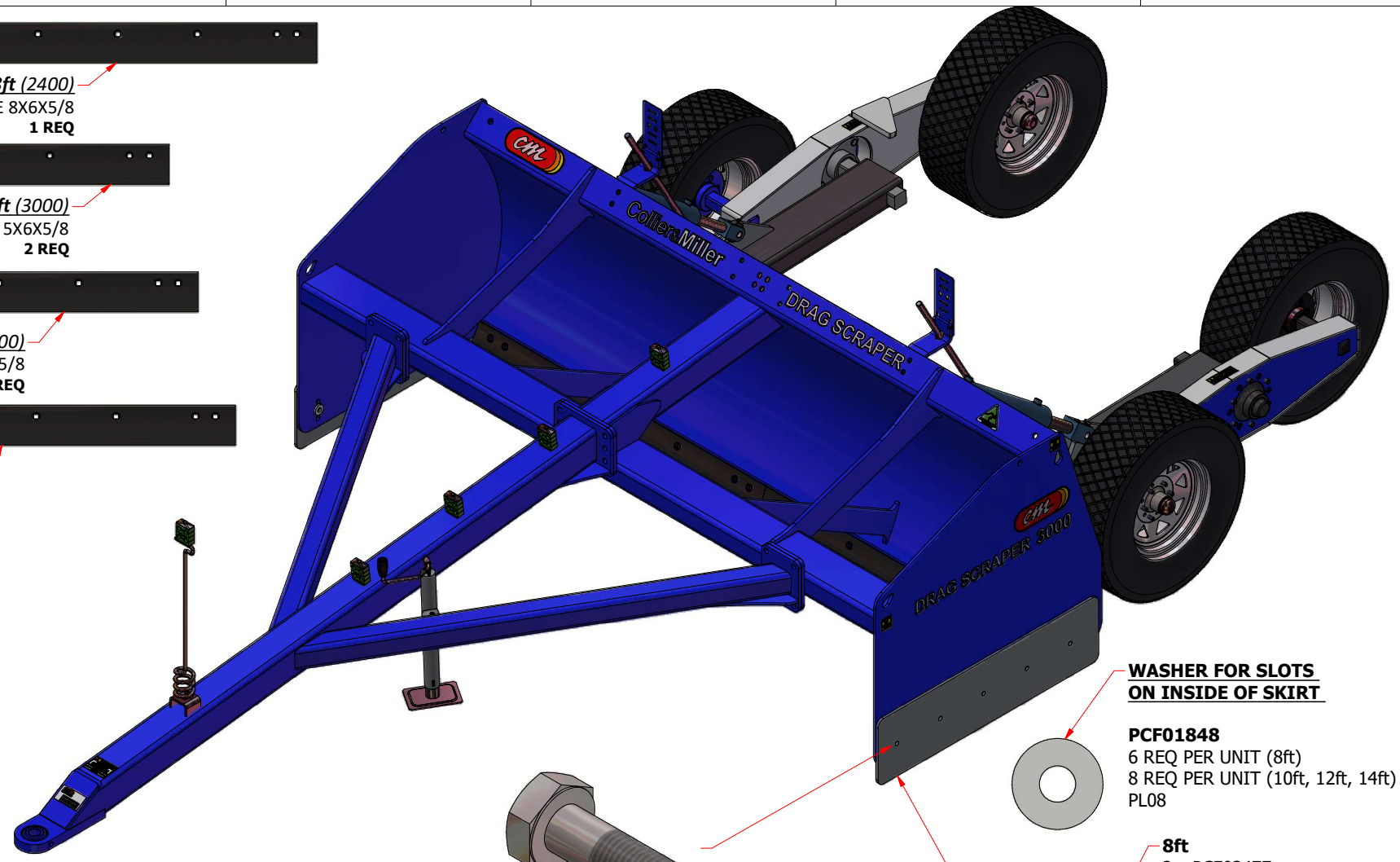

BOLTS FOR SKIRT
MC10916X50ZP
 METRIC BOLT M16 X 50 ZINC PLATED
 6 REQ PER UNIT (8ft)
 8 REQ PER UNIT (10ft, 12ft, 14ft)

+ M16 NYLOC NUTS & FLAT WASHERS

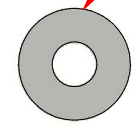

WASHER FOR SLOTS ON INSIDE OF SKIRT
PCF01848
 6 REQ PER UNIT (8ft)
 8 REQ PER UNIT (10ft, 12ft, 14ft)
 PL08

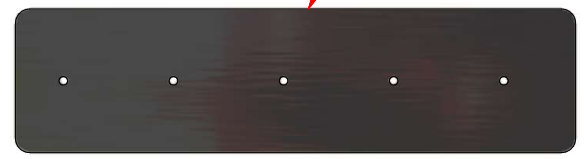

8ft
 2 x PCF03477
10ft, 12ft, 14ft
 2 x CMDSS

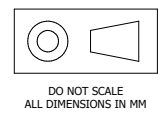

Designed by Tony Belardo	Checked by	Approved by	Date	Date 13/11/2021
 Collier & Miller Engineering			Drag scraper Consumables	
			Edition	Sheet 1 / 1