



Meet the new standard in laser-buckets for the agricultural earthmoving industry. Collier & Miller present the CME EARTHMOVER. A Scraper-Grader designed and manufactured in Australia, for high productivity and reliable land forming operations. Used with class leading high horsepower tractors, the CME EARTHMOVER is built from the ground up to out-perform and out-last the competition.

Speak to Collier & Miller regarding more information and pricing for our CME Earthmover.



STANDARD SIZES AVAILABLE

- 14' (4267mm)
- 16' (4877mm)
- 17'9" (5410mm)



Collier & Miller has over seventy years' experience in designing and manufacturing quality agricultural and industrial equipment. This product is Australian Made & Owned.



www.colliermiller.com.au

- AGRICULTURE
- CME Farm Machinery
- Landforming Machinery

8 POINT ADVANTAGE

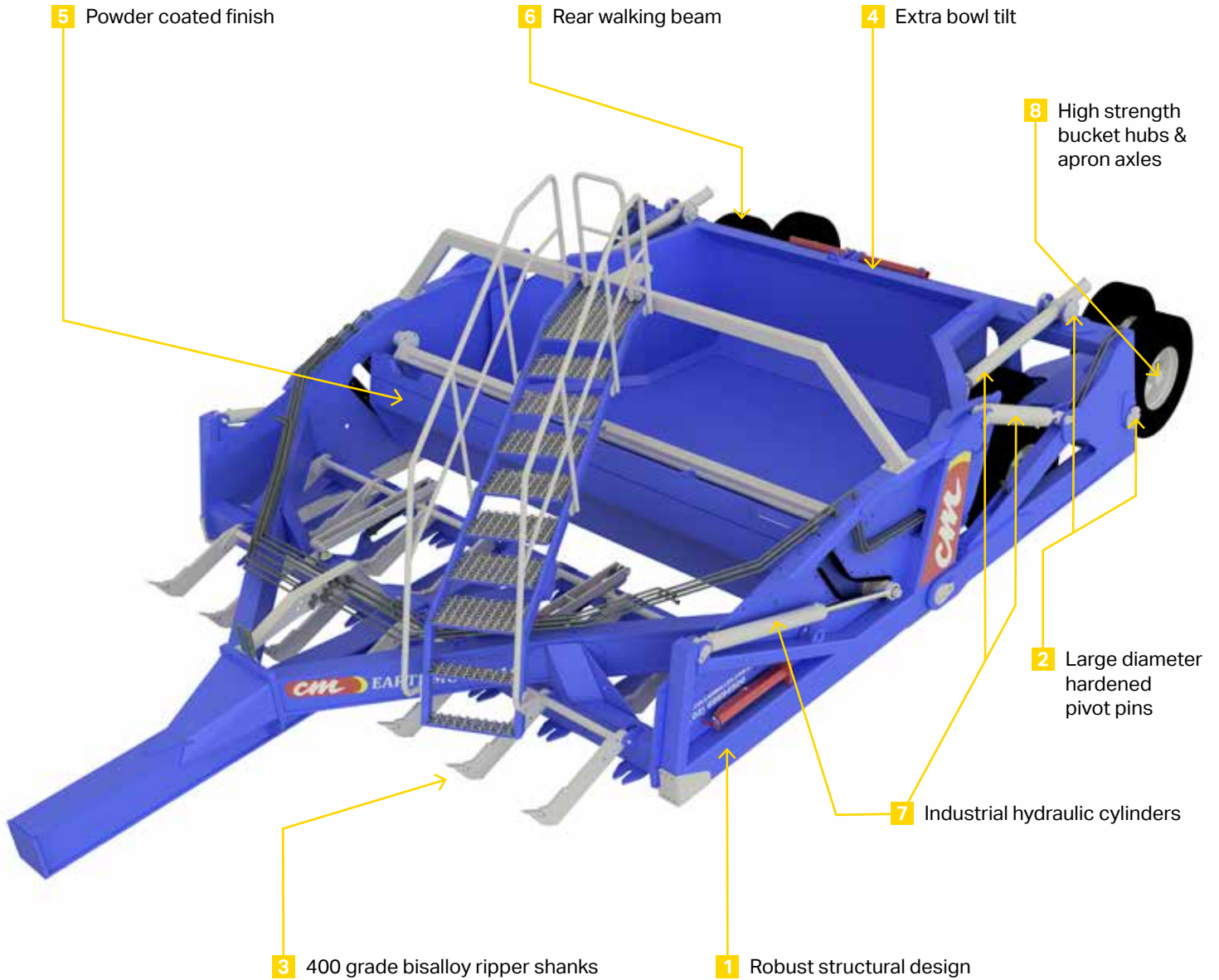

1. Robust structural design using 350 grade plate for wear & strength

2. Large diameter hardened pivot pins for reduced wear in harsh conditions

3. 400 grade bisalloy ripper shanks with high strength and wear properties

4. Extra bowl tilt for better unloading

5. Powder coated finish to protect metal surfaces from weather

6. Smooth & fast polishing ability with rear walking beam design

7. Robust industrial hydraulic cylinders with 2 1/4" shafts and large block clevis ends

8. Australian made, high strength bucket hubs & apron axles with labyrinth seal designs



MODEL	14'	16'	5400
CUTTING WIDTH	4267mm	4877mm	5410mm
DIMENSIONS			
WIDTH	4852mm	5462mm	5986mm
HEIGHT (CUTTING EDGE LEVEL)	3170mm	3170mm	3170mm
HEIGHT (CUTTING EDGE RAISED)	3800mm	3800mm	3800mm
LENGTH	10130mm	10300mm	10430mm
MAX CUTTING EDGE LIFT HEIGHT	815mm	815mm	815mm
UNLADEN MASS	14800Kg	15600Kg	17300Kg
WEIGHT DISTRIBUTION (UNLADEN)	69% 31%	69% 31%	69% 31%
WEIGHT DISTRIBUTION (LOADED)	74% 26%	74% 26%	74% 26%
MAXIMUM BOWL TILT ANGLE	55°	55°	55°
CAPACITY			
STRUCK	13.6m ³ 17.8yd ³	16.0m ³ 20.9yd ³	18.0m ³ 23.5yd ³
HEAPED	17.3m ³ 22.6yd ³	20.9m ³ 27.3yd ³	23.8m ³ 31.3yd ³
TYRES	11R22.5 Optional 295/80R22.5	11R22.5 Optional 295/80R22.5	11R22.5 Optional 295/80R22.5
AXLES	Camden Lane CM Heavy Axle	Camden Lane CM Heavy Axle	Camden Lane CM Extra Heavy Axle

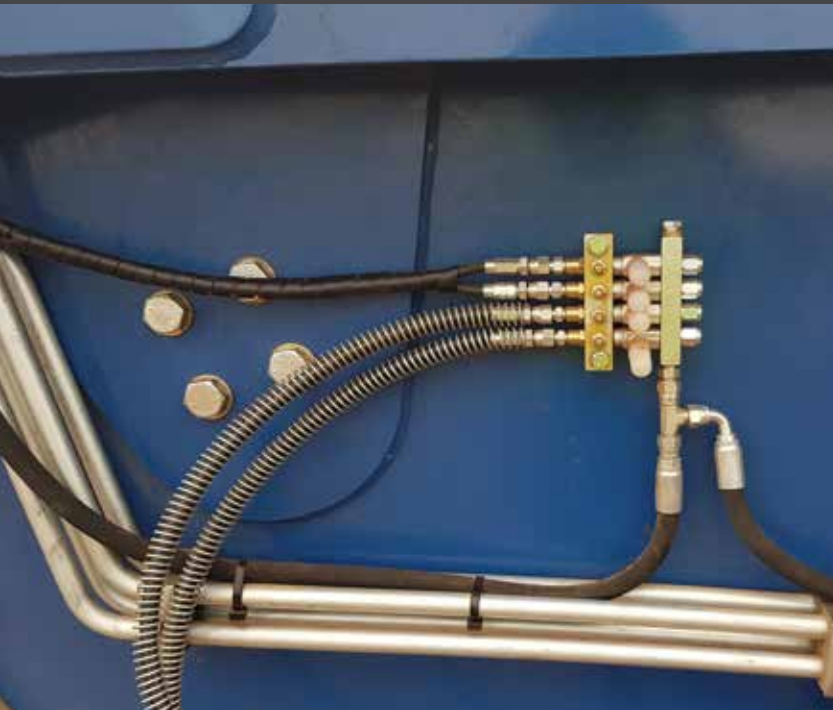

CME EARTHMOVER OPTIONAL EXTRAS

- Auto greasing
- Tractor cushion hitch and swivel ball
- Manual flip down side routers
- Hydraulic controlled side router

