

WIA

WELDMATIC 270

MIG Welder

OPERATORS MANUAL | CP146-1



From serial numbers CP1462A*

WELD WITH THE BEST.

WELDING.COM.AU

WELDING INDUSTRIES AUSTRALIA

A Division of ITW Australia Pty Ltd
ABN: 63 004 235 063

1300 300 884

Email: info@welding.com.au
welding.com.au

WELDWELL NEW ZEALAND

A Division of ITW New Zealand
NZBN: 9 429 039 833 129
GST NO: 080177186

0800 9353 9355

Email: info@weldwell.co.nz
weldwell.co.nz

CONTENTS

Section	General Information	Page
	Safe Practices	4
1	Introduction	7
2	Receiving	7
3	Specifications	8
4	Controls	9
5	Installation	10
6	Normal Welding Sequence	12
7	Basic Welding Information	12
8	General Maintenance	14
9	External Trouble Shooting	15
10	Trouble Shooting Chart	16
11	Circuit Diagrams	18
12	Assembly & Parts List Power Source	19
13	Assembly & Parts List Gun & Cable	21
14	Australian Warranty Information	23
15	New Zealand Warranty Information	25

READ FIRST

The information contained in this manual is set out to enable you to properly maintain your new equipment and ensure that you obtain maximum operating efficiency.

Please ensure that this information is kept in a safe place for ready reference when required at any future time.

When ordering spare parts, please quote the model and serial number of the power source and part number of the item required. All relevant numbers are shown in lists contained in this manual. Failure to supply this information may result in unnecessary delays in supplying the correct parts.

SAFETY

Before this equipment is put into operation, please read the Safe Practices section of this manual. This will help to avoid possible injury due to misuse or improper welding applications.

PLASTIC HANDLES ON POWER SOURCE

Please note that the handles fitted to the Weldmatic power source are intended for carrying the equipment by hand only.

DO NOT use these handles for suspending or mounting the power source in any other manner.

SAFE PRACTICES WHEN USING WELDING EQUIPMENT

These notes are provided in the interests of improving operator safety. They should be considered only as a basic guide to Safe Working Habits. A full list of Standards pertaining to industry is available from the Standards Association of Australia, also various State Electricity Authorities, Departments of Labour and Industry or Mines Department and other Local Health or Safety Inspection Authorities may have additional requirements. Australian Standard AS1674.2 provides a comprehensive guide to safe practices in welding.

Eye Protection

NEVER LOOK AT AN ARC WITHOUT PROTECTION. Wear a helmet with safety goggles or glasses with side shields underneath, with appropriate filter lenses protected by clear cover lens. This is a MUST for welding, cutting, and chipping to protect the eyes from radiant energy and flying metal. Replace the cover lens when broken, pitted, or spattered.

Recommended Shade Filter Lens

Amps	TIG	MMAW	MIG	Pulsed MIG
0-100	10	9	10	12-13
100-150	11	10	10	12-13
150-200	12	10-11	11-12	12-13
200-300	13	11	12-13	12-13
300-400	14	12	13	14
400-500	–	13	14	14
500 +	–	–	14	14

Burn Protection

The welding arc is intense and visibly bright. Its radiation can damage eyes, penetrate light-weight clothing, reflect from light-coloured surfaces, and burn the skin and eyes. Burns resulting from gas-shielded arcs resemble acute sunburn, but can be more severe and painful.

Wear protective clothing - leather or heat resistant gloves, hat, and safety-toe boots. Button shirt collar and pocket flaps, and wear cuff less trousers to avoid entry of sparks and slag.

Avoid oily or greasy clothing. A spark may ignite them. Hot metal such as electrode stubs and work pieces should never be handled without gloves.

Ear plugs should be worn when welding in overhead positions or in a confined space. A hard hat should be worn when others are working overhead.

Flammable hair preparations should not be used by persons intending to weld or cut.

Toxic Fumes

Adequate ventilation with air is essential. Severe discomfort, illness or death can result from fumes, vapours, heat, or oxygen depletion that welding or cutting may produce. **NEVER** ventilate with oxygen.

Lead, cadmium, zinc, mercury, and beryllium bearing and similar materials when welded or cut may produce harmful concentrations of toxic fumes. Adequate local exhaust ventilation must be used, or each person in the area as well as the operator must wear an air-supplied respirator. For beryllium, both must be used.

Metals coated with or containing materials that emit fumes should not be heated unless coating is removed from the work surface, the area is well ventilated, or the operator wears an air-supplied respirator.

Work in a confined space only while it is being ventilated and, if necessary, while wearing air-supplied respirator.

Vapours from chlorinated solvents can be decomposed by the heat of the arc (or flame) to form phosgene, a highly toxic gas, and lung and eye irritating products. The ultra-violet (radiant) energy of the arc can also decompose trichlorethylene and perchloroethylene vapours to form phosgene. Do not weld or cut where solvent vapours can be drawn into the welding or cutting atmosphere or where the radiant energy can penetrate to atmospheres containing even minute amounts of trichlorethylene or perchloroethylene.

Fire and Explosion Prevention

Be aware that flying sparks or falling slag can pass through cracks, along pipes, through windows or doors, and through wall or floor openings, out of sight of the operator. Sparks and slag can travel up to 10 metres from the arc.

Keep equipment clean and operable, free of oil, grease, and (in electrical parts) of metallic particles that can cause short circuits.

If combustibles are present in the work area, do NOT weld or cut. Move the work if practicable, to an area free of combustibles. Avoid paint spray rooms, dip tanks, storage areas, ventilators. If the work can not be moved, move combustibles at least 10 metres away out of reach of sparks and heat; or protect against ignition with suitable and snug-fitting fire-resistant covers or shields.

Walls touching combustibles on opposite sides should not be welded on or cut. Walls, ceilings, and floor near work should be protected by heat-resistant covers or shields.

A person acting as Fire Watcher must be standing by with suitable fire extinguishing equipment during and for some time after welding or cutting if;

- Combustibles (including building construction) are within 10 metres.
- Combustibles are further than 10 metres but can be ignited by sparks.
- Openings (concealed or visible) in floors or walls within 10 metres may expose combustibles to sparks.
- Combustibles adjacent to walls, ceilings, roofs, or metal partitions can be ignited by radiant or conducted heat.

After work is done, check that area is free of sparks, glowing embers, and flames.

A tank or drum which has contained combustibles can produce flammable vapours when heated. Such a container must never be welded on or cut, unless it has first been cleaned as described in AS.1674-2. This includes a thorough steam or caustic cleaning (or a solvent or water washing, depending on the combustible's solubility), followed by purging and inerting with nitrogen or carbon dioxide, and using protective equipment as recommended in AS.1674-2. Water-filling just below working level may substitute for inerting.

Hollow castings or containers must be vented before welding or cutting. They can explode. Never weld or cut where the air may contain flammable dust, gas, or liquid vapours.

Shock Prevention

Exposed conductors or other bare metal in the welding circuit, or ungrounded electrically alive equipment can fatally shock a person whose body becomes a conductor. Ensure that the equipment is correctly connected and earthed. If unsure have the equipment installed by a qualified electrician. On mobile or portable equipment, regularly inspect condition of trailing power leads and connecting plugs. Repair or replace damaged leads.

Fully insulated electrode holders should be used. Do not use holders with protruding screws. Fully insulated lock-type connectors should be used to join welding cable lengths.

Terminals and other exposed parts of electrical units should have insulated knobs or covers secured before operation.

If the supply cable is damaged it must be replaced by the manufacturer, their service agent or a similarly qualified person.

1 INTRODUCTION

Gas Metal Arc Welding (G.M.A.W.) is an arc welding process where a consumable wire is fed by motor driven feed rolls to a welding gun, and where welding current is supplied from the welding power source. The welding arc is struck between the work piece and the end of the wire, which melts into the weld pool. The arc and the weld pool are both shielded by gas flow from the gun, or in the case of “self shielded” wires, by gases generated by the wire core.

The process is very versatile in that by selection of the correct wire composition, diameter and shielding gas, it can be used for applications ranging from sheet-metal to heavy plate, and metals ranging from carbon steel to aluminium alloys.

The Weldmatic Fabricator has been designed to be used with consumable wires in the range from 0.6mm to 1.6mm diameter. The smaller wire sizes are used when welding at lower currents, such as sheet-metal applications. Increasing the wire diameter permits higher welding currents to be selected.

A common application of G.M.A.W. is for welding Mild Steel. In this application, a Mild Steel solid consumable wire such as AUSTMIG ES6 is used with a shielding gas of Carbon Dioxide, or Argon mixed with Carbon Dioxide. Alternatively, Flux-cored consumable wires are available in both gas shielded, and ‘gasless’ self shielding types.

Stainless steel and Aluminium can be welded with G.M.A.W. using the correct consumable wire and shielding gas.

2 RECEIVING

Check the equipment received against the shipping invoice to make sure the shipment is complete and undamaged. If any damage has occurred in transit, please immediately notify your supplier.

The Weldmatic 270 package contains:

- Weldmatic 270 Power Source CP146-2
- W64-1 Wire Feeder with 10m interconnection Cable 35mm² Weld Cable
- 10m Work Lead with Clamp
- Welding Torch 200A 3m with 0.6, 0.8, 0.9 and 1.2mm tips.
- Gas Regulator
- Gas Hose
- (This) Owner Manual CP146-40

3 SPECIFICATIONS

Manufactured to Standards	AS60974-1.
Rated Input Voltage	240 Vac, 50 Hz
Rated Primary Current	25.3Amps
Maximum Primary Current	56 Amps
Recommended Generator kVA	13.5 kVA
Rated Output @ 40°C	Duty cycle based on 10 min cycle time 270 Amp, 27.5 V, 20% duty 150 Amp, 21.5 V, 60% duty 120 Amp, 20 V, 100% duty
Welding Current	30-270 Amps
Open Circuit Voltage	17-41 V
Shipping weight	115 kg - Power source only 142 kg - Includes wirefeeder & leads
Mains Circuit Breaker Rating	25 Amps
Supply plug	15 Amp (240 V) for initial commissioning only
Fitted Supply Cable	50/0.25 Four Core, Heavy Duty PVC
Cooling	Fan on demand, fan operates only as required to cool internal components
Insulation	Class H, 140°C Rise.
Wirefeeder Circuit Breaker Rating	5 Amps

4 POWER SOURCE CONTROLS

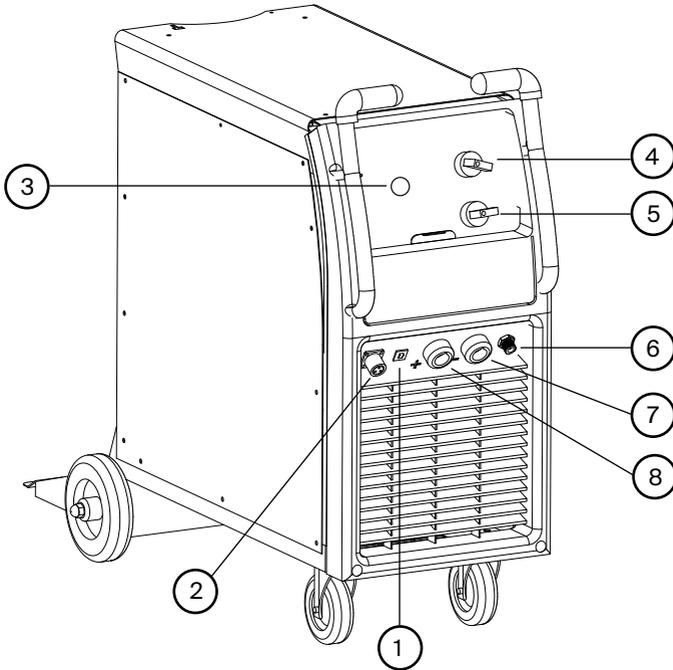

Fig 1 Power Source Controls

1 Circuit Breaker

This circuit breaker protects the 30 Vac wirefeeder supply circuit.

2 Wirefeeder Control Socket

Connector for control cable from remote wirefeeder.

3 Standby/Operate Switch

4 Coarse Voltage Control

This switch provides Coarse adjustment of the output welding voltage over four ranges.

5 Fine Voltage Control

This switch provides Fine adjustment of the output welding voltage over four steps.

6 Gas Outlet

Connector for shielding gas hose from remote wirefeeder.

7 Negative Welding Output Terminal

8 Positive Welding Output Terminal

5 INSTALLATION

Connection to Electrical Mains Power Supply

NOTE. All electrical work shall only be undertaken by a qualified electrician.

The Weldmatic 270 is factory fitted with a 3 metre, 3 core 2.5 mm² Heavy Duty PVC mains power supply cable with moulded 3 pin, 15 Amp, Single Phase plug.

15 Amp Supply Limited Output

To operate the machine with the 15 Amp plug from a 15 Amp mains supply, the output of the machine needs to be limited, so as not to exceed primary current I_{eff} 15 Amp.

A Weld voltage selection of D-1, and operation at 22% duty cycle (i.e. 2 min 12 sec on, 7 min 48 sec off) will maintain an effective input current I_{eff} of 15 Amp.

The output will be limited to 200 Amp (based on conventional load). The maximum input limited to 32 Amp.

A 15 Amp socket outlet installation, typically supplied with a 20 Amp “C” curve circuit breaker, will be able to safely supply this.

Maximum Rated Output

To achieve the rated output of 270 Amp, 20% duty the machine requires maximum primary current I_{max} 56 Amp and effective primary current I_{eff} 25.3 Amp.

The machine needs to be fitted with a plug of 25 Amp capacity or greater, and a supply circuit capacity of 25 Amp or greater.

The minimum recommended supply circuit breaker rating for a Weldmatic 270 is 25 Amps. For Australian and New Zealand installation a 32 Amp plug is the closest suitable size. The supply circuit will also need to be rated at 32 Amp.

Successful Operation

Successful operation will depend on a number of factors:

- Variation in circuit breaker thresholds
- Ambient temperature
- Number of previous circuit breaker operations
- Actual weld conditions – can result in higher weld currents
- Repeated starts – can result in high inrush currents raising the circuit breaker threshold.

Repeated circuit breaker operation at weld start can sometimes be overcome by using a “D” curve circuit breaker.

To reduce nuisance tripping, a higher rated circuit breaker can be selected, but the supply circuit wiring capacity must be increased to suit.

The current rating of the supply cable depends on cable size and method of installation. Refer to AS/NZS 3008.1, Table 9.

Supply Cord Replacement

If it becomes necessary to replace the mains power supply flexible cable, use only cable with the correct current rating. Access to the supply terminals is gained by removing the power source side panels.

The replacement cable must be fitted and retained in the same manner as the original.

Output Voltage Polarity

The design of the Weldmatic 270 allows selection of the output voltage polarity.

Positive Wire

G.M.A.W. with solid consumable wires is carried out with the work piece Negative and the welding wire Positive.

To setup for this condition, connect the 'WORK' lead plug into the (-) output socket on the Power Source, and the 'WELDING' lead from the wirefeeder into the (+) socket on the Power Source, as in Figure 2

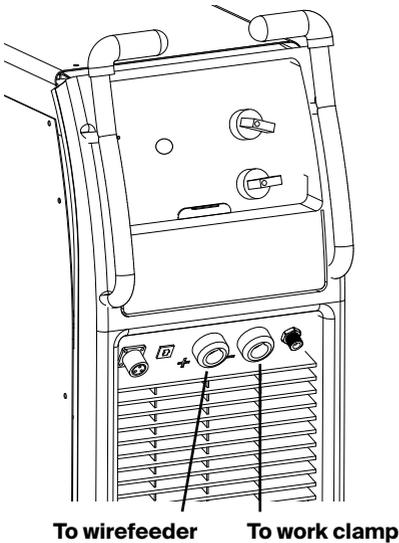

Fig 2 Positive Wire

Negative Wire

Some 'self-shielded' flux cored consumable wires are operated with the work piece Positive and the consumable wire Negative. Refer to the manufacturers data for the particular consumable wire to be used.

To setup for this condition, connect the 'WORK' lead plug into the (+) output socket on the Power Source, and the 'WELDING' lead from the wirefeeder into the (-) socket on the Power Source, as in Figure 3

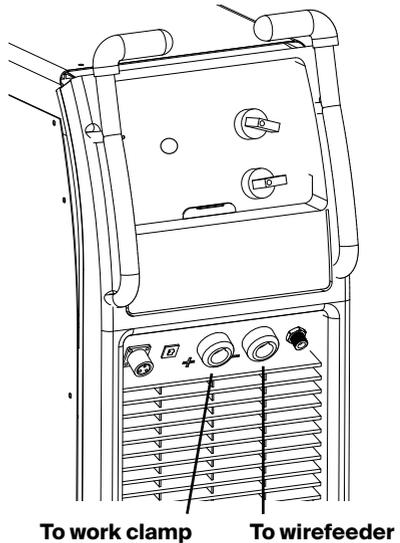

Fig 3 Negative Wire

Fitting the Gas Cylinder

Place the gas cylinder on the tray at the rear of the welder. Retain the cylinder with the chain provided.

Fit the gas regulator to the cylinder. DO NOT apply grease or oil to these joints.

Fit the end of the gas inlet hose from the composite cable to the connector supplied with the gas regulator, and secure with the clamp also supplied.

Remote Wirefeeder

The remote wirefeeder is connected to the Weldmatic Fabricator power source via the composite cable interconnecting lead. Check all connections are firmly made to ensure good electrical contact, and to prevent gas leaks.

6 NORMAL WELDING SEQUENCE

Weld Start

Closing the welding gun switch initiates this sequence of events:

- The gas valve is energised and gas flow commences and continues for any pre-gas time set
- The power source contactor function is initiated. Welding voltage is applied between the work piece and the consumable wire
- The wire drive motor is energised
- The wire touches the work piece, and the arc is established.

Weld End

Releasing the gun switch initiates this sequence of events:

- The wire drive motor is de-energised, and is dynamically braked to a stop
- After a short pre-set period, known as the 'burn-back' time, the Power-source contactor function is released. This period ensures that the consumable wire does not 'freeze' in the weld pool
- At the completion of any post-gas time set, the gas valve is de-energised and the flow of shielding gas ceases.

7 BASIC WELDING INFORMATION

Choice of Shielding Gas

The choice of shielding gas is largely determined by the consumable wire to be used. Many proprietary shielding gas mixtures are available.

The recommended shielding gases for use with the Weldmatic 270 are:

- Mild Steel: Argon + 5 to 25% Carbon Dioxide;
100% CO₂
- Aluminium: Argon;
- Stainless Steel: Argon + 1 to 2% Oxygen.

Consult your gas supplier if more specific information is required.

Shielding Gas Flow Rate

In G.M.A. welding, one function of the shielding gas is to protect the molten weld pool from the effects of oxygen in the atmosphere. Without this protection the weld deposit becomes 'honeycombed' in appearance, an effect which is described as weld porosity.

In draft-free conditions the gas flow rate required to give adequate protection is typically 10-12 litres/min. In situations where drafts cannot be avoided, it may be necessary to increase this rate up to 20 litres/min, and/or to provide screening of the work area.

Weld porosity can also be caused by air entering the gas stream through a damaged hose, loose gas connection, or from restriction in the nozzle, such as from excess build-up of spatter.

When welding aluminium, particular care must be taken with all aspects of shielding gas delivery and workpiece preparation in order to avoid weld porosity.

Establishing a Weld Setting

Once the consumable wire type, wire size and shielding gas have been chosen, the two variables that are adjusted in order to obtain a the desired weld setting are;

- Wirefeed speed,
- Welding arc voltage.

The wirefeed speed determines the welding current; increasing the speed increases the current, and decreasing it decreases current.

The selected wirefeed speed must be matched with sufficient arc voltage; a speed increase requires an increase of arc voltage.

If the voltage is too low the wire will stub and stutter, and there will not be a steady arc. If the voltage is too high the arc will be long with metal transfer occurring as a series of large droplets.

Important: Do not operate the Voltage Control switches during welding.

The weld setting should be chosen to suit the application and the thickness of the metal to be welded. It is important to check that the deposited weld provides sufficient strength to suit the application.

A “good” weld will have the characteristics illustrated in Figure 4. The weld has penetrated into the parent metal, fusing the root of the joint where the two plates meet, and the weld blends smoothly into the side walls.

A “bad” weld is shown in Figure 5. The weld has not penetrated the joint root, and there is poor side wall fusion. This lack of fusion would normally be corrected by increasing the arc voltage, or by increasing both wirefeed speed and arc voltage to achieve a higher current weld setting.

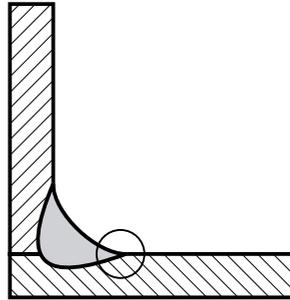

Fig 4 “Good” Weld

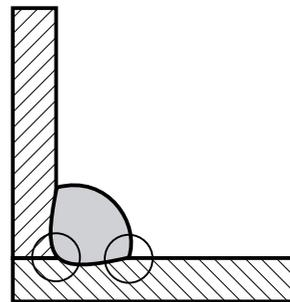

Fig 5 “Bad” Weld

8 GENERAL MAINTENANCE

Gun Position

For “down hand” fillet welding, the gun is normally positioned as shown in Figure 6 below with the nozzle end pointing in the direction of travel.

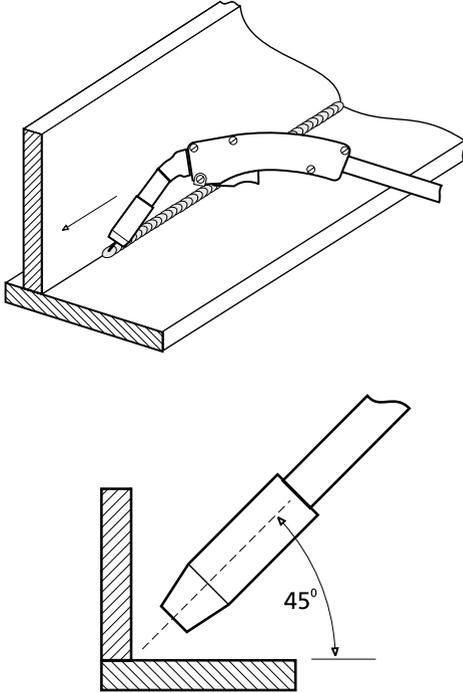

Fig 6 Gun Position

Before removing the power source covers, ENSURE that the equipment is disconnected from the mains power supply. When the equipment is energised LETHAL VOLTAGES are present on the electrical components enclosed.

Dust

Care should be taken to prevent excessive build-up of dust and dirt within the welding power source. It is recommended that at regular intervals, according to the prevailing conditions, the equipment covers be removed and any accumulated dust be removed by the use of a dry, low pressure compressed air, or a vacuum cleaner. The machine should be blown out with compressed air at least every 12 months as grinding dust can settle on PCB componentry causing failure. Failure to maintain machines may void warranty.

Wirefeed

In order to obtain the most satisfactory welding results from the G.M.A.W. process, the wirefeed must be smooth and constant. Most causes of erratic wirefeed can be cured by basic maintenance. Check the General Maintenance section of the Wirefeeder Operators Manual for more details.

9 EXTERNAL TROUBLE SHOOTING

If you are in Australia and the following checks do not identify the fault condition, the equipment should be returned to a WIA Service agent. Phone 1300 300 884 for details of your nearest service agent.

If you are in New Zealand and the following checks do not identify the fault condition, the equipment should be returned to the original place of purchase with proof of purchase, or contact Weldwell on 06 8341 600.

10 TROUBLE SHOOTING CHART

Problem	Likely Reason	Outcome
All Transformer Models		
No welding current, no display.	The machine is not turned on at both the mains supply and the machine power switch.	If confirmed that the machine is switched on correctly, test the same outlet using a known serviceable appliance.
Mains Circuit breaker nuisance tripping during welding.	Mains Circuit breaker inadequately rated, or duty cycle exceeded.	The circuit breaker may be rated for leff (effective current). If Weld output is greater than the 100% rating the machine will require mains current higher than leff The duty cycle should be observed and understood.
Machine continually cuts out on thermal overload	The machine duty cycle has been exceeded.	Leave the machine energized, with the fan running until the machine has cooled sufficiently. The duty cycle should be observed and understood.
No welding current, but display on.	The connections may not be made securely.	Ensure all connections are in position and securely made.
Machine gives poor quality weld.	The polarity of the electrode/return cables is incorrect.	Polarity should be confirmed for the process/wire type in use.
	The return lead contacts, or workbench surface requires cleaning.	The return lead contacts and connections should be inspected and cleaned, and the workbench cleared of waste materials.
Machine works fine on mains power but does not work when connected to a generator.	Generator cannot provide high peak cycle currents for inverter	Use larger kVA generator or sometimes a different band generator will work.
Machine works fine on mains power but does not work when connected with extension lead.	Extension leads creating additional resistance, and voltage drop	Use larger cable size, and keep extension lead as short as possible.

Problem	Likely Reason	Outcome
GMAW/MIG Models		
The machine feeds slowly and then speeds up after 3-5 seconds.	Creep mode is selected, or machine has a permanent creep mode function.	Some models have a creep mode function that cannot be adjusted. Other models have a push button selection for creep mode on/off.
Nothing happens for first x seconds after trigger is pulled.	Pre gas is selected to x seconds.	Allow for Pre Gas time, or adjust time.
The arc starts normally but then stops x seconds.	Spot time is selected to x seconds.	Spot time selection should be adjusted to 0 seconds.
The arc does not stop after trigger is released.	Latch mode is selected.	Latch mode should be switched off.
Motor continues to run once arc is extinguished.	Latch mode is selected.	Latch mode should be switched off.
Weld is contaminated with small bubbles (presence of porosity).	Air in the gas hose. The torch gas hose has not been purged sufficiently.	Purge the system and confirm sufficient gas flow through the regulator.
	The gas hose is not securely connected at the machine or at the regulator.	Ensure the gas connections from regulator through to the torch connection are sufficiently tightened.
	Air is being drawn into arc through torch nozzle	Remove nozzle, check O ring on torch head, check condition of insulator in nozzle
Wire feed stutters and arc is erratic. Also, motor turns correctly under no load.	Torch consumables are blocked/partially blocked.	Liners and contact tips are consumable and wear over time.
	Rusty MIG wire.	Replace the torch liner and reduce wire feed tension.
Presence of porosity at weld start.	The torch gas hose has not been purged sufficiently.	Purge the system and confirm sufficient gas flow through the regulator.

11 CIRCUIT DIAGRAMS - POWER SOURCE

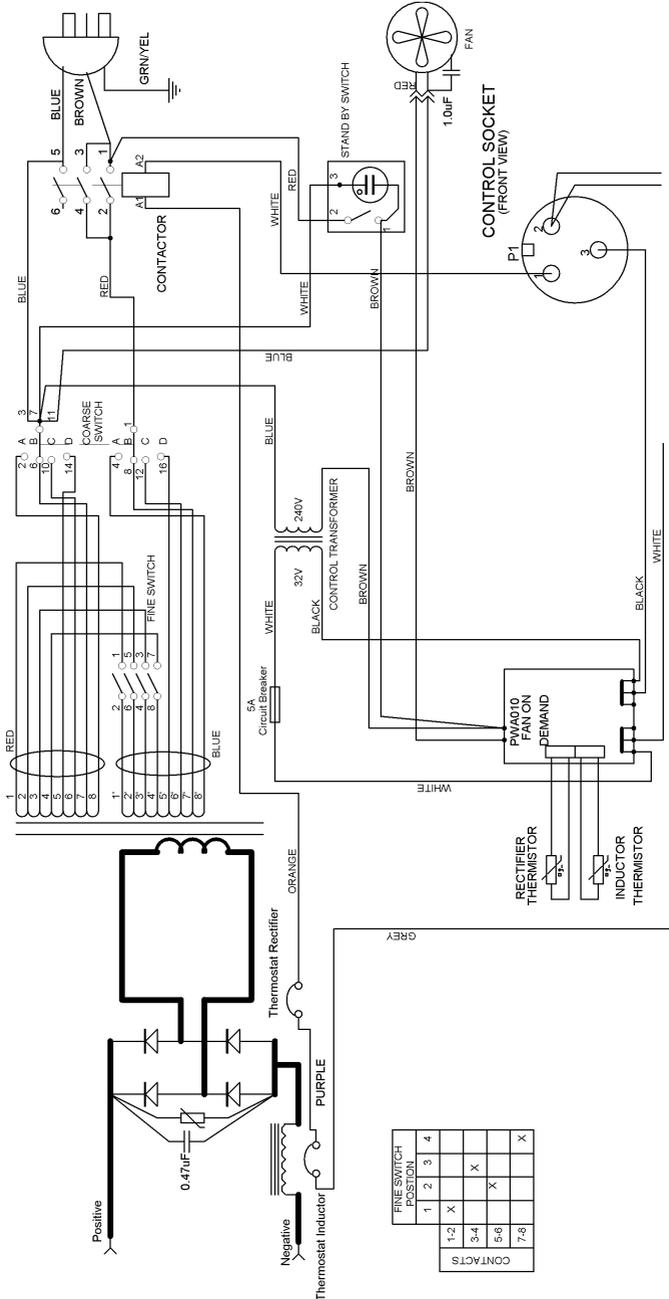

Fig 7 Power Source Circuit Diagram

12 ASSEMBLY AND PARTS LIST - WELDMATIC 270 POWER SOURCE

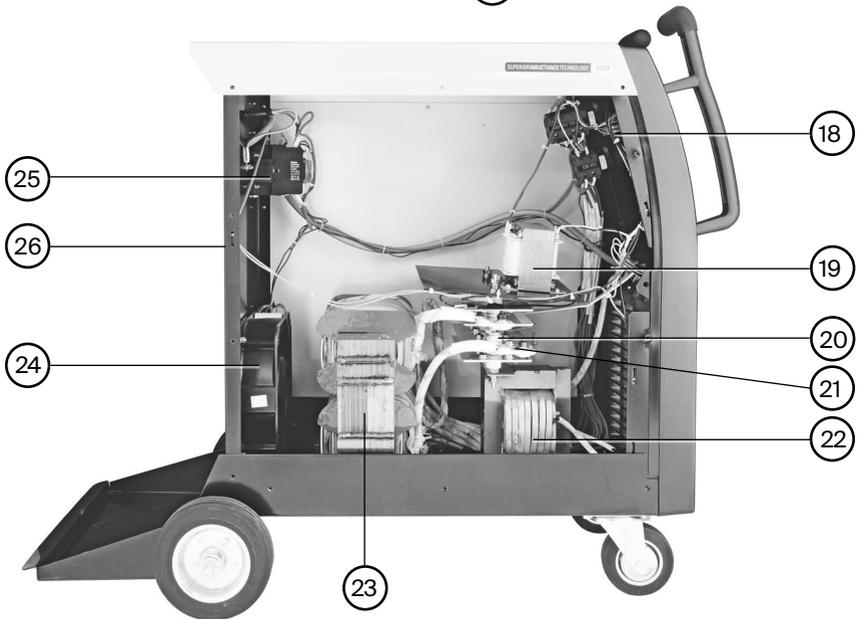
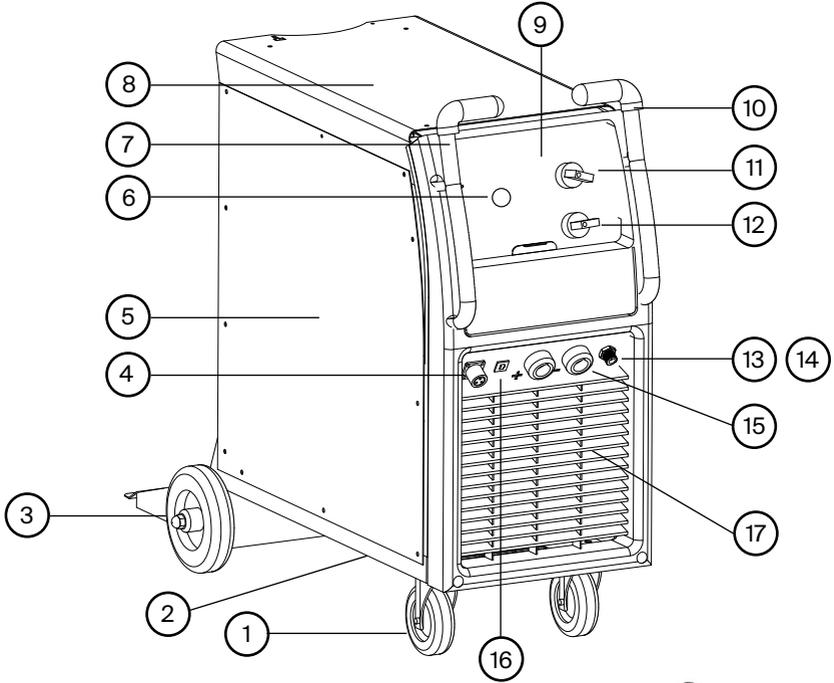

Fig 8 Weldmatic 270 Power Source Assembly

WELDMATIC 270 PARTS LIST

Item #	Part #	Description	Qty
1	WHL002	Wheel, Rubber, Castor	2
2	PAN094	Base	1
3	WHL003	Wheel, Rubber, Fixed	2
4	E0053	Control Socket, 3 Pin	1
5	PAN097	Side Panel	2
6	E0042	Switch, Standby/Operate	1
7	MR231554	Handle Left	1
8	PAN096	Top Panel	1
9	PAN092	Front Panel	1
10	MR231553	Handle Right	1
11	E0055	Switch, Coarse, 4 Position	1
12	E0054	Switch, Fine, 4 Position	1
13	TC265	5/8" UNF Nipple	1
14	TC266	5/8" UNF Nut	1
15	CX58	Socket, Dinse	2
16	E0024	Circuit Breaker, 5 Amp	1
17	MR230304	Plastic Front	1
18	PWA010	Fan On Demand PCB	1
19	L0022	Control Transformer	1
20	D0031	Rectifier	1
21	E0056	Thermostat	1
22	IND029	Inductance Assembly	1
	E0057	Thermal Overload (included with Inductance Assembly)	1
23	TFM061	Welding Transformer Assembly, Wired	1
24	FAN008	Fan Assembly	1
25	EO058	Contactors	1
26	PAN095	Back Panel	1
Not Shown	R0028	Fan On Demand Thermistor	2

13 ASSEMBLY AND PARTS LIST - GUN AND CABLE ASSEMBLY

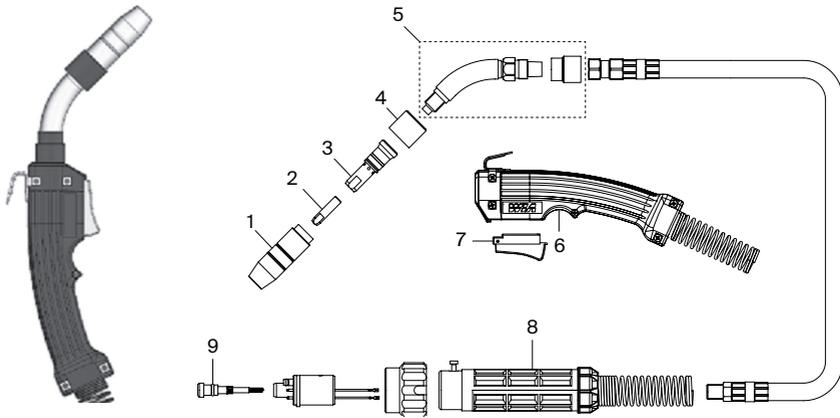

Fig 9 GUN001 (200 amp) Gun and Cable Assembly

Item #	Part #	Description
1	BE4392	Nozzle, Brass, Tapered
2	see 'TIPS' page 22	Contact Tip
3	BE4335	Gas Diffuser (Head)
4	BE4323	Cap
5	BEQT2-45 BEQT2-30	Body Tube, 2", 45° (supplied) Body Tube, 2", 30°
6	GUN002	Handle Kit (includes both halves, screws & trigger)
7	GUN003	Trigger
8	GUN005	Rigid Casing
9	BEL3B-15 BE43115X	Steel Liner 0.9 - 1.2mm Nylon Liner 0.9 - 1.2mm

Tips

To replace liner: Disconnect gun/cable assembly at the Euro adaptor. Remove nozzle (1) and head (3). Withdraw old liner from the wirefeeder end. Insert new liner and refit gun/cable assembly to the wirefeeder.

At the gun end, compress the liner within the gun cable, then cut it 20mm past the end of the body tube (5). Refit head, tip and nozzle.

Wire diameter	Short Series (25mm)
0.6mm	BE7497
0.8mm	BE7488
0.9mm	BE7489
1.0mm	BE7496
1.2mm	BE7490

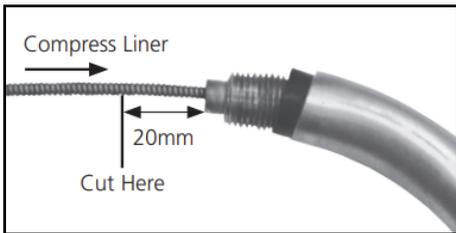

Fig 10 Replacing the gun cable liner

14 AUSTRALIAN WARRANTY INFORMATION



WIA Weldmatic MIG Equipment

3 Year Gold Shield Warranty Statement

Effective 1st January 2022

Welding Industries of Australia (WIA) warrants to the original retail purchaser that the Weldmatic welding machine purchased (Product) will be free from defects in materials and workmanship for a period of 3 years from the date of purchase of the Product by the customer. If a defect in material or workmanship becomes evident during that period, Welding Industries of Australia will, at its option, either:

- Repair the Product (or pay for the costs of repair of the Product); or
- Replace the Product.

In the event of such a defect, the customer should return the Product to the original place of purchase, with proof of purchase, or contact Welding Industries of Australia on 1300 300 884 to locate an authorised service agent.

Products presented for repair may be replaced by refurbished products of the same type rather than being repaired. Refurbished parts may be used to repair the product. Replacement of the product or any part does not extend or restart the Warranty Term. The repair of your products may result in the loss of any user-generated data. Please ensure that you have made a copy of any data saved on your product.

Any handling and transportation costs (and other expenses) incurred in claiming under this warranty are not covered by this warranty and will not be borne by Welding Industries of Australia. Welding Industries of Australia will return the replacement product, if original found to be faulty, freight free to the customer.

This warranty covers the Weldmatic power source and wirefeeder only, and does not extend to the regulator, gun assembly or accessories included in the original purchase package.

The obligation of Welding Industries of Australia under this warranty is limited to the circumstances set out above and is subject to:

- The customer being able to provide proof of purchase of the Product and the purchase price paid for the Product;
- The relevant defect in materials or workmanship;
- The Product not having been altered, tampered with or otherwise dealt with by any person in a manner other than as intended in respect of the relevant Product; and
- The Product not having been used or applied in a manner that is contrary to customary usage or application for the relevant Product or contrary to any stated instructions or specification of Welding Industries of Australia.

For products purchased in Australia

Our goods come with guarantees that cannot be excluded under the Australian Consumer Law. You are entitled to a replacement or refund for a major failure and for compensation for any other reasonably foreseeable loss or damage. You are also entitled to have the goods repaired or replaced if the goods fail to be of acceptable quality and the failure does not amount to a major failure. The benefits given by this warranty are in addition to other rights and remedies which may be available to the customer under any law in relation to goods and services to which this warranty relates.

Warranty provided by:

Welding Industries of Australia

(ABN 63 004 235 063)

A Division of ITW Australia Pty Ltd

5 Allan Street, Melrose Park
South Australia 5039

1300 300 884

Email: info@welding.com.au

Web: www.welding.com.au



WIA Weldmatic MIG Equipment

3 Year Gold Shield Warranty Statement

Effective 1st January 2022

WIA Weldmatic MIG Equipment purchased in New Zealand have identical warranty conditions as Australia, with the below conditions:

In the event of defects listed in the Australian warranty conditions, the customer should return the Product to the original place of purchase, with proof of purchase, or contact Weldwell on 0800 9353 9355.

The warranty shall not apply to parts that fail due to normal wear.

For customers located in New Zealand, you can contact:

Weldwell New Zealand

Division of ITW New Zealand

64 Thames Street
Napier 4110
New Zealand

0800 9353 9355

Email: info@weldwell.co.nz

Web: www.weldwell.co.nz

NOTES:

NOTES:



WELDING INDUSTRIES AUSTRALIA

A Division of ITW Australia Pty Ltd

ABN: 63 004 235 063

1300 300 884

Email: info@welding.com.au

welding.com.au

WELDWELL NEW ZEALAND

A Division of ITW New Zealand

NZBN: 9 429 039 833 129

GST NO: 080 177 186

0800 9353 9355

Email: info@weldwell.co.nz

weldwell.co.nz

CP146-40 RevB

WELD WITH THE BEST.

WELDING.COM.AU