



HIGH-LIFT JACK

Distributed by Kincrome Group www.kincromegroup.com

Owner's Assembly and Operating Manual

| | |
|-------------------------------------|---|
| SPECIFICATIONS | 2 |
| IMPORTANT SAFETY INFORMATION | 3 |
| UNPACKING AND ASSEMBLING JACK | 3 |
| Unpacking Carton | 3 |
| Testing Operation | 3 |
| OPERATING JACK..... | 4 |
| Preparing Work Area | 4 |
| Lifting Vehicle | 5 |
| Working on Vehicle | 5 |
| Lowering Vehicle | 6 |
| MAINTENANCE AND STORAGE | 7 |
| Lubricating..... | 7 |
| Cleaning | 7 |
| Storage..... | 7 |
| Repairing Jack | 7 |

SPECIFICATIONS

| | |
|--------------------|---------|
| Working Load limit | 1050 KG |
| Height lowered | 130 mm |
| Height raised | 1070 mm |
| Handle Length | 1200 mm |
| Total Weight: | 13 KG |
| Part Number | K12069 |

IMPORTANT SAFETY INFORMATION

The use of a vehicle jack has inherent dangers to avoid risk of personal injury or property damage make sure you are fully aware of the operating instructions for this product, the recommendations in the vehicle owners manual for jacking of your vehicle prior to lifting the vehicle. Do not exceed maximum lifting capacity of this jack. This jack is intended for automotive use only. Be aware that large or heavy vehicles may exceed jack's stated capacity check vehicle owners manual or contact the vehicle manufacturer. Do not use for vehicle maintenance or wheel removal, a high lift jack is designed for aiding in vehicle recovery and winching. Never use to raise any structure or building, Do not lift any human load and do not get under a raised vehicle.

UNPACKING AND ASSEMBLING JACK

Unpacking Carton

Place carton in a clear, open area such as garage floor. Remove jack from carton. No pre-assembly is required so please take this time to familiarise yourself with the jack, its function and these operating instructions

Testing Operation

Briefly test jack operation as follows

BEFORE using to lift any

Load. Step 1 place jack on a firm level surface. Step 2 place ratchet control lever in the lifting position Step 3 raise the lifting nose by gently pumping the handle up and down.

The jack will click in and out as the lifting pins engage and disengage with the jack with each up and down stroke of the jack.

Danger: the handle becomes weight bearing during the lifting and lowering process.

Caution: this jack must have a minimum load of 50 kg on it to lower step by step, otherwise the lifting mechanism will slide down to the base plate dropping your load.

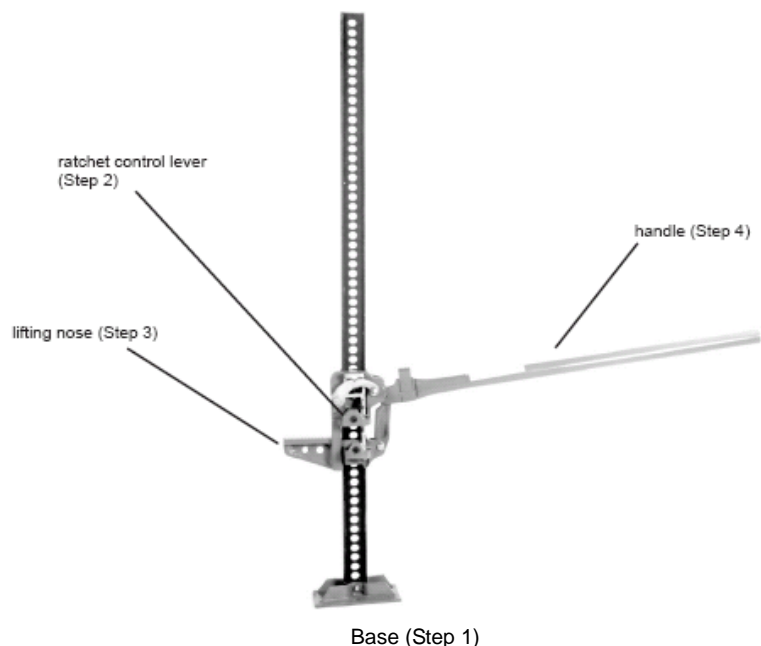

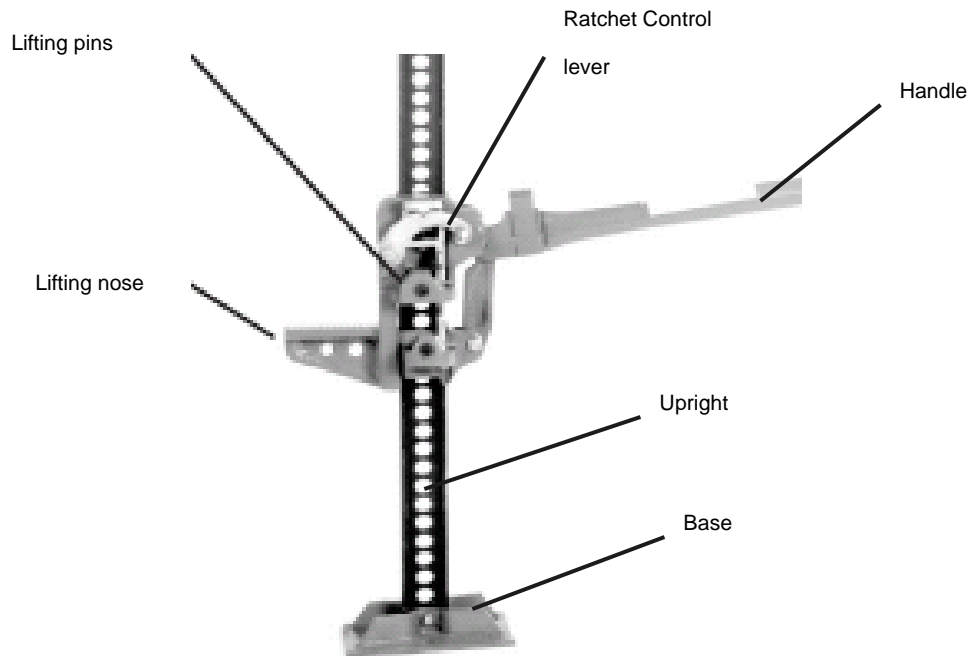

OPERATING JACK

The use of a high lift Jack has inherent dangers to avoid risk of personal injury or property damage make sure you are fully aware of the operating instructions for this product, the recommendations in this manual can not cover all eventualities this Jack is designed and intended for use by properly trained and experienced personnel. If you are not familiar with the proper and safe operation of a High Lift Jack, do not use until proper training and knowledge has been obtained.

Preparing Work Area

Before using jack, it is important to prepare work area properly. Follow this procedure each time the jack is used to help prevent property damage and or serious injury.

- 1.) Thoroughly inspect jack for damage or wear before each use. Briefly test operation of unloaded jack before using to lift any load. If jack is damaged or is malfunctioning **DO NOT LIFT ANY LOAD** until the problem is corrected.
- 2.) Consult vehicle owner's manual for safety precautions, jacking procedure, vehicle weight, recommended jack type, and location of jack support areas on vehicle.
- 3.) The working load limit of the jack is 1050 kg. **NEVER EXCEED WORKING LOAD LIMIT OF JACK.**
- 4.) Consider the load the vehicle is carrying this can greatly increase the overall weight of the vehicle.
- 5.) Clear children and others from work area before moving or lifting vehicle. Another adult should be nearby for extra safety and assistance but must be clear of vehicle as it is moved or lifted.
- 6.) No person should remain in a vehicle that is being lifted moved or lifted, No person should enter a vehicle which is supported by a jack or by vehicle support stands. No person should lean into a vehicle which is supported by a jack or by vehicle support stands.
- 7.) Clear obstructions from work area. Working in tight or cluttered work areas is dangerous.
- 8.) Be sure jack and vehicle are on solid, dry, and level ground so upright is pointing straight up. Uneven sloped or soft surfaces create hazardous working conditions and dangerously impeded the function of the

jack.

- 9.) With vehicle in proper position, set vehicle's parking brake or emergency brake and put gearshift in park (manual transmissions should be placed in lowest gear). TURN VEHICLE IGNITION OFF AND TO THE "LOCK" POSITION making sure steering wheel locks.
- 10.) Do not rely on vehicle transmission or brakes to hold vehicle in position. Chock all wheels of vehicle not being lifted off the ground to prevent vehicle rolling. Using wedge-shaped blocks that tire cannot roll over, position one chock tight against the tyre in both forward and reverse rolling paths.
- 11.) Plan location of jack, make sure jack will be contacting a flat area of vehicle. Consult vehicle owner's manual for location of jack support areas. Never use on curved or tubular surfaces as these can more easily slide off the jack causing the load to fall leading to property damage personal injury or even death.

Lifting Vehicle

Lifting a vehicle using a jack can be dangerous. Follow all instructions and precautions below. Do not lift any vehicle with its engine running or start any vehicle that is supported by jack or jack stands.



- 1.) With lifting nose completely lowered, place jack into position beneath a suitable jack support area of vehicle.
- 2.) Engage the jack by pulling up on the ratchet control lever
- 3.) Pump jack handle slowly until lifting nose just begins to contact support area on underside of vehicle.
- 4.) Inspect position of lifting nose beneath support area, making sure it is centered and properly engaging support area.
- 5.) Check the base is firmly on the ground capable of holding the weight. A plate (not included) of material able to hold the weight can be used to spread the load over a larger area.
- 6.) The load will be lifted on each down stroke of the handle, the load will push up against the handle on each stroke, keep head and body away from the path of the handle, if your hands should slip off the handle it may fly up causing serious injury or death.
- 7.) Continue pumping handle slowly with both hands on the handle until vehicle is lifted to desired height.
- 8.) Pay attention to lifting nose position as vehicle is being raised to be sure there is no danger of support area slipping off.

Working on Vehicle

Any vehicle being supported by a jack creates a potentially hazardous working environment.

Do not try to move a vehicle that is supported by a jack. Never place any part of your body beneath a vehicle supported by a jack. Be careful of forces applied to vehicle such as torque on a nut or bolt. These forces could cause vehicle to become unstable. Do not turn vehicle ignition or attempt to start any vehicle supported by jack.

Lowering Vehicle

Before lowering vehicle, be sure area under and near vehicle is clear of all persons and obstructions.

- 1.) With jack handle in upright position push down on the ratchet control lever, the jack handle will move rapidly up if the ratchet control lever is placed in the lowering position with the handle not properly stowed in the upright position.
- 2.) The load will be lowered on each up stroke of the handle; the load will push up against the handle on each stroke, keep head and body away from the path of the handle, if your hands should slip off the handle it may fly up causing serious injury or death.
- 3.) Check to be sure lifting saddle is centered under support area. Slowly pump handle to lower vehicle.
- 4.) Carefully control speed of descending vehicle. Lowering a vehicle too fast can cause property damage or injury.
- 5.) This jack must have a minimum load of 50 kg on it to lower step by step, otherwise the lifting mechanism will slide down to the base plate dropping your load.



Winching

Always use two straps or chains which have a higher working load capacity than the jack.

- 1.) Attach one end of a chain or tow strap to the object to be winched, securely attached the other end to the top of the Jack using an equally rated shackle
- 2.) Take another strap or chain and attach to a stable object.
- 3.) Attach the second chain or strap to the lifting nose of the jack. Never attach to the hole in the lifting nose, the base of the jack or the holes in the up right.
- 4.) Operate the jack slowly as you would for lifting.

DANGER: The use of a High Lift Jack as a winch has inherent dangers to avoid risk of personal injury or property damage make sure you are fully aware of the operating instructions for this product, the recommendations in this manual can not cover all eventualities this Jack is designed and intended for use by properly trained and experienced personnel. If you are not familiar with the proper and safe operation of a High Lift Jack, do not use until proper training and knowledge has been obtained.

Be aware that rolling loads can increase dramatically due to resistance; a bogged vehicle can require a force much greater than its overall weight to winch free. Always consider the working load limit of this jack and never exceed this limit.

MAINTENANCE AND STORAGE

Lubricating

Moving parts on jack should be lubricated occasionally with a light penetrating oil, Silicone, or Teflon spray lubricants, to maintain efficient operation. Apply oil or spray to joints on handle hinges, lifting pins, and springs. Wipe away excess oil with soft cloth.

Cleaning

Jack should be kept clean using water pressure, air pressure or firm brush and then wiped clean with soft cloth. Dry thoroughly and lubricate Jack after cleaning. Do not use gasoline, kerosene, or other such solvents or any abrasive cleanser as cleaning agents and solvents.

Storage

Before storage, clean and lubricate Jack; store jack level, in a clean environment preferably indoors, in a dry area to protect jack from moisture.

Repairing Jack

There are no user serviceable parts except as outlined above. Only trained, licensed and certified repair personnel should attempt any repairs or replacing of parts. Any modifications to this jack, except those performed by the manufacturer, or their designee, will void all warranties both written and implied.

Part List:

1. Top Clamp-Clevis Bolt
2. Top Clamp-Clevis
3. Steel Standard(Bar)
4. Steel Handle W/Cotter Pin
5. Handle Socket
6. Pin
7. Hex Bolt
8. Connecting Rod
9. Small Runner
10. Srew Bolt
11. Base
12. Climbing Pin Spring (2 required)
13. Climbing Pin (2 required)
14. Cross Pin (2 required)
15. Reversing Switch Cam Bar and Spring
16. Cap Screw W/Washer
17. Reversing Latch
18. Reversing Switch Spring
19. Large Runner
20. Running Gear (assembled)

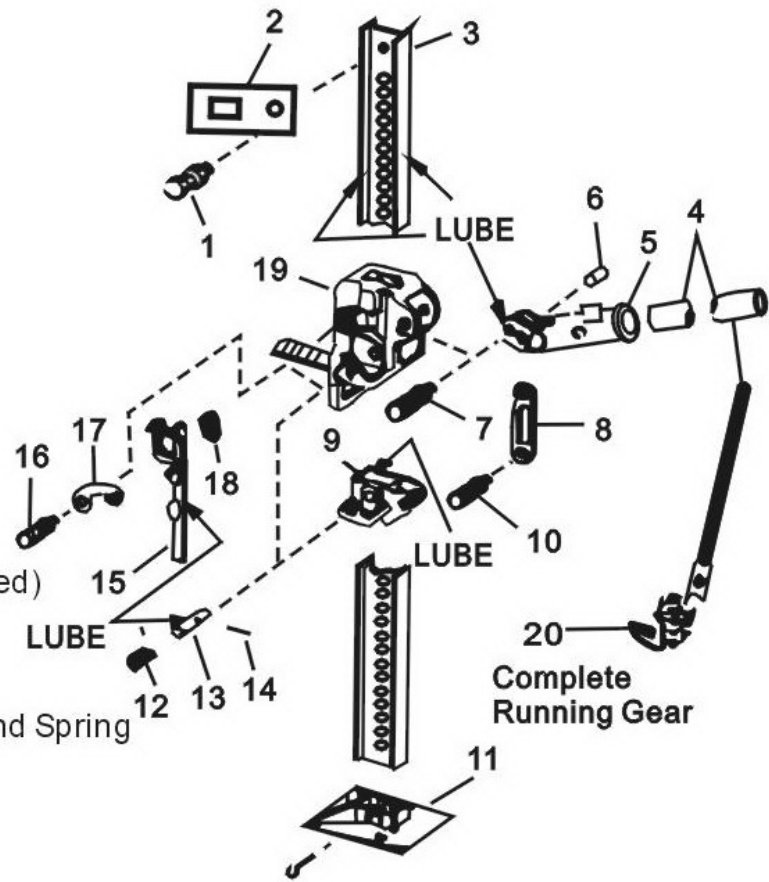

Distributed by Kincrome Group www.kincromegroup.com
3 Lakeview Drive Scoresby Victoria
Phone: 1300 657 528

