

Technical Data

Stainless Steel Self-Priming Jet Pumps

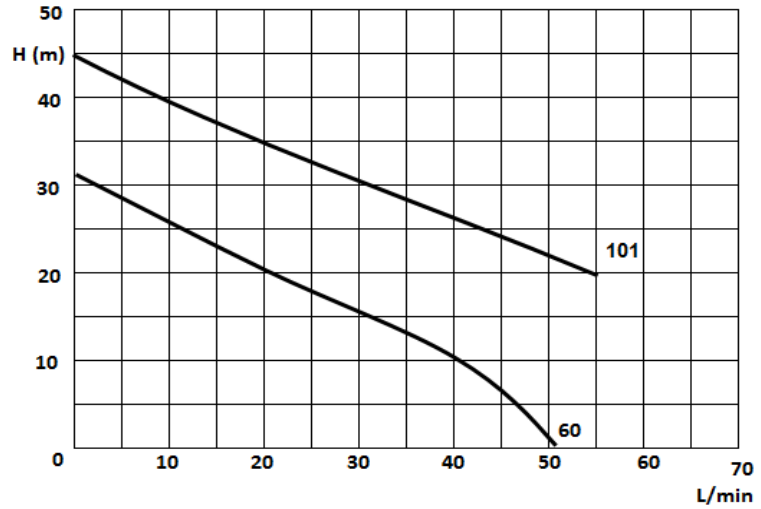

JSL60, JSL101



Description:

JSL60 /JSL101: This model features excellent hydraulic performance, and is the ideal pump for domestic water tank, shallow sand spears and small garden applications. It is recommended that these pumps are used to carry only chemically pure liquids (water) free of foreign matters, with a temperature not higher than 40°C. Maximum ambient temperature should not exceed 45°C. Horizontal axis pump with Noryl Impeller and diffuser, 304 grade stainless steel pump body and backing plate, base support of die cast alloy, Venturi tube of Noryl with 20% glass fibre, AISI 416 stainless steel shaft and mechanical seal of ceramic/graphite. **Electric motors:** closed type with external cooling fan (TEFC), IP44 safety class. F insulation. Single phase motors fitted with thermostat-controlled safety micro switches to avoid undesirable damages to the motor.

Specifications:

Model	Power			Speed rpm	Suction Max. (m)	Operating pressure Max. (kpa)	Package Dimensions (mm) & Weight (Gross)			
	HP	kW	V				L	W	H	Kg
JSL60	0.6	0.44	240	2850	8	300	530	210	290	8.7
JSL101	1	0.75	240	2850	8	450	580	240	260	11.7

Construction:

Pump	Pump Body	Stainless Steel
	Impeller	Noryl
	Diffuser & Jet	Noryl
	Mech. Seal	Ceramic / Graphite
	Pump Shaft	Stainless Steel
Motor	Motor Housing	Aluminium
	Motor Shaft	Carbon Steel
	Insulation	Class F
	Protection	IP44
	Cooling	External (TEFC)

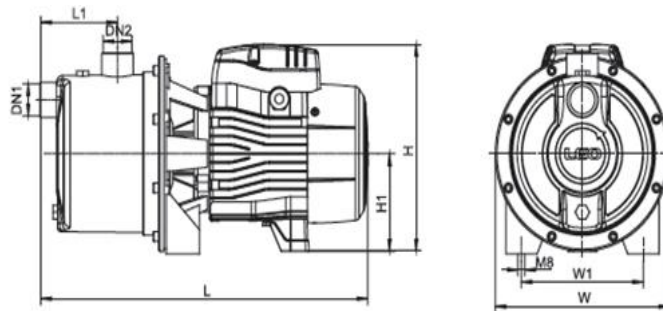

Model	Dimensions (mm)								
	L	W	H	L1	W1	H1		Inlet	Outlet
JSL60	335	200	225	90	140	125		25mm	25mm
JSL101	400	200	235	90	140	125		25mm	25mm